

01/1/70  
04P6842

# ANNALS of CARNEGIE MUSEUM

CARNEGIE MUSEUM OF NATURAL HISTORY

4400 FORBES AVENUE • PITTSBURGH, PENNSYLVANIA 15213

VOLUME 50

18 SEPTEMBER 1981

ARTICLE 15

## SYSTEMATICS OF *ANTROZOUS DUBIAQUERCUS* (CHIROPTERA: VESPERTILIONIDAE), WITH COMMENTS ON THE STATUS OF *BAUERUS* VAN GELDER

MARK D. ENGSTROM<sup>1</sup>

DON E. WILSON<sup>2</sup>

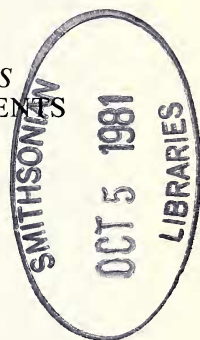

### ABSTRACT

Geographic variation within *Antrozous (Bauerus) dubiaquercus* is reviewed based on examination of pelage and multivariate analyses of external and cranial measurements of 29 specimens from the Islas Tres Marias, Nayarit, Mexico, and five specimens from the mainland of Middle America. As much variation exists among mainland specimens as is found between the nominal mainland subspecies (*A. d. meyeri*) and that from the Islas Tres Marias (*A. d. dubiaquercus*), and the species is regarded as monotypic. Systematic relationships between the subgenera *Antrozous* and *Bauerus* are discussed based on several suites of characters. Differentiation between these taxa equals that found among most genera of vespertilionid bats and *Bauerus* is accorded generic rank. The karyotype of *B. dubiaquercus* is reported for the first time.

### INTRODUCTION

Evolutionary relationships within and among American nyctophiline bats are poorly understood. One Recent genus, *Antrozous*, comprising two subgenera, *Antrozous* and *Bauerus*, and three species, *A. (A.) pallidus*, *A. (A.) koopmani*, and *A. (B.) dubiaquercus*, is recognized

<sup>1</sup> Address: Department of Wildlife and Fisheries Sciences, Texas A&M University, College Station, TX 77843.

<sup>2</sup> Address: U.S. Fish and Wildlife Service, National Museum of Natural History, Washington, D.C. 20560.

Submitted 29 July 1980.

in the New World (Koopman and Jones, 1970; Pine et al., 1971; Martin, 1974; Jones et al., 1977).

Geographic variation in mensural characters of *A. pallidus* was reviewed by Martin (1974). Variation within the rare Cuban bat, *A. koopmani*, was described by Silva Taboada (1976). Although the nomenclature of populations of *A. dubiaquercus* has been in a state of flux since Van Gelder (1959) described the taxon, a review of variation among populations has not been possible because this species is rare in collections. Two nominal subspecies have been recognized—*A. d. dubiaquercus* from the Islas Tres Marias off the coast of Nayarit in western Mexico and *A. d. meyeri* from Veracruz and Honduras on the mainland of Middle America (Pine et al., 1971).

Since the description of *A. dubiaquercus* (Van Gelder, 1959) and reports of three mainland specimens by Pine (1966, 1967) and Pine et al. (1971), we have collected 42 specimens from the Islas Tres Marias and two specimens from mainland Mexico. This additional material, including karyotypic data from some specimens, led us to review variation within *A. dubiaquercus* and reevaluate systematic relationships within *Antrozous*.

#### MATERIALS AND METHODS

In the morphological analysis, we used 34 specimens of *A. dubiaquercus* housed in the National Museum of Natural History (USNM), Carnegie Museum of Natural History (CM), and the Texas Cooperative Wildlife Collection, Texas A&M University (TCWC) from the following localities: MEXICO. *Nayarit*: Islas Tres Marias, Maria Cleofas, 6 ♂, 8 ♀ (USNM); Maria Magdalena, 5 ♂, 7 ♀ (USNM), Maria Madre, 2 ♂, 1 ♀ (USNM). *Jalisco*: 12.5 mi SW (by road) Talpa de Allende, 4200 ft, 1 ♂ (CM). *Veracruz*: Ojo de Agua del Rio Atoyac, 1400 ft, 1 ♀ (TCWC); Rio Quezalapan, 2 mi E Lago Catemaco, 1 ♀ (TCWC). HONDURAS. 40 km E Catacamas, 1 ♂, 1 ♀ (TCWC). All specimens are adults (as defined by the fusion of the epiphyses of the metacarpals and phalanges) except the holotype of *A. d. meyeri* which is a subadult female. We also examined 13 specimens (USNM) preserved in fluid or as skeletons, and the holotype and three paratypes in the American Museum of Natural History.

The following measurements are those taken by field collectors: total length (TL) and lengths of tail (LT), hindfoot (LHF), and ear (LE). We measured length of forearm (LFA) according to Handley (1959). The following cranial measurements were taken as defined by Cockrum (1962): greatest length of skull (GLS); condyle-premaxillae length (CPL); postpalatal length (PPL); length of maxillary toothrow (LMT); zygomatic breadth (ZB); mastoid breadth (MB); least interorbital constriction (LIC); and greatest width across upper molars (GWM).

The 29 specimens from the Islas Tres Marias were combined as a single sample to test for differentiation between the sexes using the TTEST procedure of the Statistical Analysis System (SAS; Goodnight, 1979). Two multivariate programs of the Numerical Taxonomy System (NT-SYS; Rohlf and Kishpaugh, 1972) were used to assess the phenetic affinities of individual specimens. Cluster and principal components analyses were chosen because neither program requires any *a priori* assumptions concerning the within sample variation (Rohlf, 1971). Samples of *A. dubiaquercus* from the mainland are so small that calculation of within group variation is impossible. Accordingly, each specimen was considered an Operational Taxonomic Unit (OTU).

Correlation and distance matrices among OTU's were generated from standardized character values. The unweighted pair-group method based on arithmetic averages (UPGMA) was used to cluster each matrix and the results were summarized as dendrograms. In all analyses the coefficient of cophenetic correlation (a measure of the distortion of the original matrix in producing the phenogram) was larger for the distance phenogram and only these results are presented.

Principal components analysis (PCA) was performed on the correlation matrix to obtain vectors, which indicate the major trends of variation among the OTU's. Standardized values of the OTU's were then projected onto the first three axes to depict the variation among OTU's relative to the total variation within the group.

We karyotyped four specimens from Maria Madre, Maria Magdalena, and Maria Cleofas, Islas Tres Marias, and the one specimen from Jalisco. Karyotypes were prepared in the field from bone marrow cells obtained from the humeri of bats according to methods modified from Patton (1967) and Baker (1970). Terminology regarding placement of the centromere is that of Patton (1967).

## RESULTS

### *External and Cranial Morphology*

Results of the TTEST procedure for secondary sexual variation in the Islas Tres Marias sample are summarized in Table 1. Females averaged larger than males in all cranial characters except LIC (which varies inversely with size of skull) and in all external characters except LT and LE. Females were significantly larger than males ( $P < 0.05$ ) in five of eight cranial measurements (GLS, ZB, MB, CPL, GWM) and the sexes were separated in subsequent analyses. Specimens from the Islas Tres Marias and from Veracruz are similar in external and cranial dimensions and are unlike the individuals from Honduras (especially the female) and Jalisco (Table 1).

Multivariate analyses for each sex using external and cranial characters and using cranial characters only yielded similar results. Results derived from the entire set of characters are illustrated in Figs. 1 and 2. Analyses of cranial characters are discussed only when they differ from analyses using all characters.

Cluster analyses of the distance matrices of females and males are illustrated in Fig. 1A and Fig. 1B, respectively. The respective coefficients of cophenetic correlation were 0.918 and 0.897. Most of the females are arranged in one large cluster of similar-sized bats from the Islas Tres Marias and the two individuals from Veracruz (designated as group a in Fig. 1A). When only cranial characters are analyzed the Veracruz specimens fall near the center of the main cluster. No pattern of variation corresponding to the distribution of specimens among Maria Magdalena, Maria Cleofas, and Maria Madre of the Islas Tres Marias is apparent. The female from Honduras is smaller in most cranial characters (Table 1) than the island specimens or those from Veracruz and is a distant outlier (designated as b in Fig. 1A) of group a.

Cluster analysis of males yielded three groups (designated a, b, and

Table 1.—Measurements and summary statistics for samples of *Antrozous dubiaquercus*. *T* statistics given for the *Islas Tres Marias* sample were used to test for sexual dimorphism and asterisks indicate levels of significance (\**P* < 0.05; \*\**P* < .01). Abbreviations of characters are defined in text. Values in the Veracruz sample are for specimens from localities near Lago Catemaco and Ojo de Agua del Rio Atoyac, respectively. *N* = 12 for zygomatic breadth of males in the *Islas Tres Marias* sample.

Character	Islas Tres Marias		Jalisco	Veracruz	Honduras	
	Females (N = 16) mean ± 1 SD (range)	Males (N = 13) mean ± 1 SD (range)	Male (N = 1) value	Females (N = 2) values	Female (N = 1) value	Male (N = 1) value
TL	122.1 ± 3.05 (115–126)	121.8 ± 3.14 (117–126)	104	107, 120	115	115
	T = - .31					
LT	50.9 ± 1.77 (47–53)	52.2 ± 2.58 (49–57)	46	46, 55	48	47
	T = 1.50					
LHF	12.8 ± .75 (12–14)	12.5 ± .66 (12–14)	11	12, 13	10	10
	T = -1.03					
LE	24.9 ± 2.45 (20–27)	25.5 ± 1.33 (23–27)	22	24, 25	23	22
	T = .93					
LFA	55.2 ± 1.51 (50.50–57.05)	54.3 ± 1.43 (50.55–55.80)	50.20	52.00, 55.90	50.70	47.90
	T = -1.67					
GLS	21.01 ± .24 (20.55–21.50)	20.67 ± .27 (20.25–21.25)	19.25	21.20, 21.50	20.55	19.90
	T = -3.66**					
ZB	13.11 ± .23 (12.65–13.45)	12.86 ± .21 (12.50–13.20)	12.50	13.05, 12.90	12.85	12.40
	T = -2.88**					
MB	10.04 ± .15 (9.75–10.35)	9.86 ± .15 (9.50–10.10)	9.60	10.00, 9.95	9.65	9.40
	T = -3.17**					
CPL	18.75 ± .22 (18.35–19.15)	18.42 ± .31 (17.95–19.15)	17.65	18.90, 18.70	18.20	17.70
	T = -3.35**					
PPL	6.73 ± .18 (6.20–7.00)	6.62 ± .14 (6.30–6.85)	6.30	6.50, 6.20	6.20	5.80
	T = -1.65					
LIC	3.98 ± .08 (3.85–4.10)	4.01 ± .10 (3.85–4.20)	4.05	3.95, 3.90	4.20	4.15
	T = .79					
LMT	7.16 ± .08 (7.05–7.30)	7.09 ± .13 (6.90–7.40)	6.60	7.15, 7.25	7.05	6.95
	T = -1.64					
GWM	8.09 ± .14 (7.75–8.25)	7.94 ± .11 (7.80–8.15)	8.00	8.30, 8.20	7.75	7.75
	T = -2.40*					

c in Fig. 1B). Group a comprises the specimens from Maria Madre and Honduras, which are slightly smaller in external and cranial dimensions than those from Maria Cleofas and Maria Magdalena. Group b consists of a mixture of specimens from Maria Cleofas and Maria Magdalena. The male from Jalisco (group c) is smaller in most cranial measurements than any other specimen analyzed (see Table 1). In cranial dimensions, this individual is most similar to the female specimen from Honduras but appears proportionately smaller in several characters (most notably GLS, CPL, LMT). Although morphologically adult, the sagittal crest of the Jalisco specimen is less developed and the skull is more delicate than in any other bat examined.

Results of the PCA are given in Table 2 and Fig. 2. Each character, except least interorbital constriction, is highly and positively correlated with principal component I in all analyses, causing OTU's to be dispersed along this component on the basis of overall size.

Along principal components I and II, females (Fig. 2A) from the Islas Tres Marias and Veracruz form one group and the single OTU from Honduras appears as a distant outlier, paralleling the results of the cluster analysis. The position of the specimen from Honduras on principal component I reflects the small size of this individual. The two specimens from Veracruz separate slightly from the remainder of the OTU's along principal component III which is most correlated with the characters TL, LFA, PPL, LIC, and GWM. When cranial characters alone are considered, only the specimen from near Lago Catemaco, Veracruz, can be differentiated along the third axis.

In males (Fig. 2B), the island OTU's form one diffuse cluster along principal component I and the specimens from Honduras and Jalisco appear as outliers. The males from Jalisco and Maria Madre separate from one another and from the remaining OTU's along principal component II (highly correlated with TL, LHF, GLS, ZB, MB, and GWM), whereas the specimen from Honduras is distinct along principal component III (highly correlated with GLS, ZB, PPL, LIC, and LMT).

When cranial characters alone are considered for males, positions among the island OTU's with respect to the first three principal components are similar to those obtained using all characters; however, the specimen from Honduras does not separate from the island OTU's along principal components I or III but groups with the Isla Maria Madre specimen along all three principal components. Cranial similarities between these specimens probably account for their close association in the cluster analysis (Fig. 1B). The position of the Jalisco specimen is similar in both PCA runs but its distinctness along principal components I and II is emphasized when only cranial characters are considered.

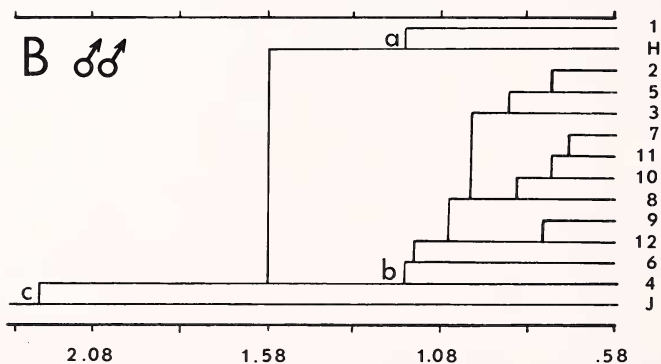
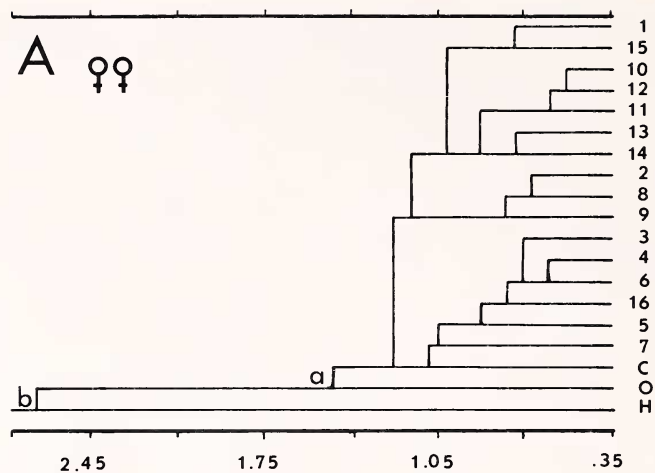

Fig. 1.—Distance phenograms resulting from cluster analyses of females and males of *Antrozous dubiaquercus*, considering each specimen as an OTU. Lower case letters indicate clusters mentioned in text. A) Females; localities of specimens numbered 1 =

Table 2.—Eigenvalues, percentage of total variance, and character loadings for the first three components resulting from Principal Components Analyses of females and males of *Antrozous dubiaquercus*. Percentage of total variance is cumulative. Abbreviations of characters are defined in text.

Statistics and characters	Females			Males		
	I	Components II	III	I	Components II	III
Eigenvalue	6.8	1.9	1.3	6.6	1.7	1.5
% total variance	52.4	67.4	77.3	50.9	64.0	75.6
TL	0.46	-0.26	0.70	0.79	-0.43	0.09
LT	0.50	-0.54	0.19	0.71	-0.03	0.27
LHF	0.87	-0.29	-0.07	0.55	-0.34	0.28
LE	0.47	-0.58	-0.21	0.68	0.03	0.09
LFA	0.71	0.10	0.31	0.73	0.08	-0.09
GLS	0.92	0.02	-0.27	0.87	-0.33	-0.30
ZB	0.83	0.45	0.12	0.64	0.48	-0.45
MB	0.86	0.37	0.10	0.81	0.49	-0.14
CPL	0.94	0.11	-0.12	0.88	-0.14	-0.10
PPL	0.57	0.00	0.48	0.80	0.17	0.42
LIC	-0.43	0.70	0.32	-0.55	-0.14	-0.75
LMT	0.86	-0.05	-0.23	0.75	-0.27	-0.52
GWM	0.68	0.56	-0.35	0.32	0.82	-0.01

### Karyology

The diploid number ( $2n$ ) of *A. dubiaquercus* is 44 and the number of autosomal arms (FN) equals 52 (Fig. 3). The autosomal complement comprises two large, one medium-sized, and two small pairs of meta-centric chromosomes and a graded series of 16 pairs of medium-sized to small acrocentrics. The X chromosome is a medium-sized submetacentric and the Y is a small acrocentric. No chromosomal variation was found among individuals.

### DISCUSSION

#### Geographic Variation

As noted by Bogan (1978), variation between populations of bats inhabiting the Islas Tres Marias and those inhabiting the mainland is

←

Maria Madre, 2-8 = Maria Magdalena, and 9-16 = Maria Cleofas, Islas Tres Marias. Abbreviated localities of specimens designated as C = Lago Catemaco, Veracruz, O = Ojo de Agua, Veracruz, and H = Honduras. B) Males; localities of specimens numbered 1 = Maria Madre, 2-6 = Maria Magdalena, and 7-12 = Maria Cleofas, Islas Tres Marias. Abbreviated localities of specimens designated as J = Jalisco and H = Honduras.

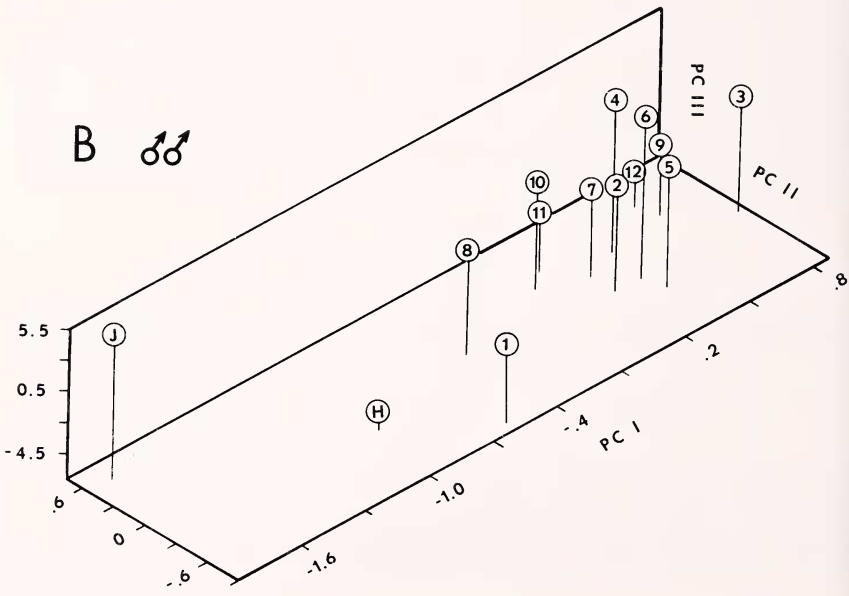
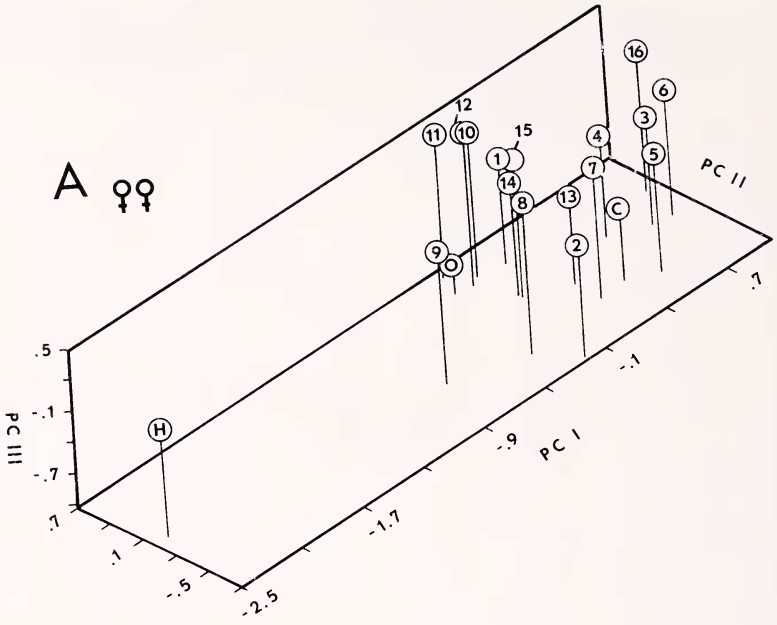



of especial interest because of the high degree of endemism on the islands. However, patterns of variation among populations of *A. dubiaquercus* are difficult to interpret.

Specimens from the Islas Tres Marias are morphometrically inseparable from those from Veracruz except on the basis of color. The male and female from the same locality in Honduras appear to differ as much from one another in several external and cranial characters as either does from specimens from other geographic areas. Mensurally, the bat from Jalisco was the most divergent specimen examined although it is from the nearest mainland locality to the Islas Tres Marias. As much variation is evident among some mainland specimens as appears between those from the islands and the mainland. Thus, the current assignment of one subspecific epithet to populations inhabiting the Islas Tres Marias (*dubiaquercus*) and another to all populations inhabiting the mainland (*meyeri*) is arbitrary.

Mensural variation within *A. dubiaquercus* is not concordant with variation in color. All mainland specimens have dark ears, rhinaria, and flight membranes, whereas exposed membranes in specimens from the Islas Tres Marias are paler. Variation in color of dorsal pelage is similar, with darker specimens occurring on the mainland and somewhat paler specimens on the islands, although the dorsal coloration of the specimen from Jalisco and the one from Ojo de Agua, Veracruz, is similar to that of individuals from the Islas Tres Marias.

Differences in color among island and mainland specimens probably reflect adaptations to local environmental conditions. Individuals from the Islas Tres Marias occupy tropical deciduous forest (Fig. 4A), whereas specimens from the mainland were taken in lowland tropical evergreen forest (Fig. 4C) with the exception of the bat from Jalisco, which was collected in moist pine-oak forest. Presumably, background coloration in deciduous forest (at least during the dry season) is paler than that in more mesic, evergreen forest, and overall coloration of *A. dubiaquercus* probably is responding directly to selective pressures to match these backgrounds.

#### *Relationship of Antrozous to Bauerus*

Van Gelder (1959) described *Antrozous dubiaquercus* based on five specimens from the Islas Tres Marias, Nayarit, and assigned the

---

←  
Fig. 2.—Projections of individual specimens of *Antrozous dubiaquercus* onto the first three components for: A, females; and B, males. Identifying numbers and letters are referred to localities (see Fig. 1). The scale of each component is drawn relative to the percent influence of that component on the total variance (see Table 2).

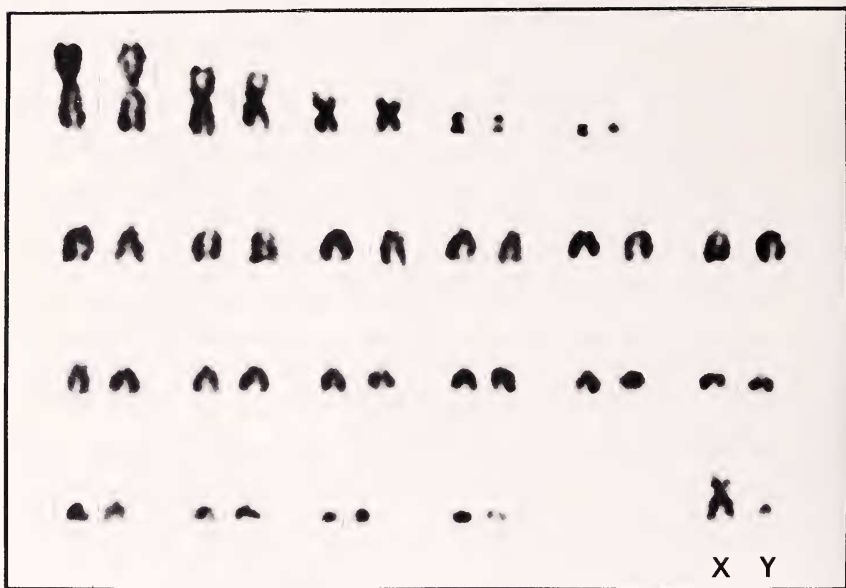

Fig. 3.—Karyotype of a male *Antrozous dubiaquercus* ( $2n = 44$ ,  $FN = 52$ ).

species to a new subgenus, *Bauerus*. White (1969) proposed that *Bauerus* be recognized at the generic level based on the presence of an extra lower incisor in *dubiaquercus*. White (1969) included *A. koopmani* within *Antrozous* because it lacks a third lower incisor; however, Martin (1974) and Silva Taboada (1976) noted similarities of this species to *Bauerus*. Pine et al. (1971) described several differences in the morphology of the phallus between *Antrozous* (represented by *A. pallidus*) and *Bauerus* but noted that the presence of a third lower incisor in *Bauerus* was not constant and proposed that the differences separating the higher taxa would best be recognized at the subgeneric level (a third lower incisor is present on at least one ramus of 43 of the 44 additional specimens examined by us and was found in all of the specimens examined by Pine et al., 1971, except the holotype of *A. dubiaquercus*). In the same paper, they regarded the mainland taxon *A. (B.) meyeri* as a subspecies within *A. (B.) dubiaquercus*. Martin (1974) noted additional external differences between the phalli of *A. (A.) pallidus* and *A. (B.) dubiaquercus* but proposed no taxonomic changes. No phallic data are available for *A. koopmani*.

*Antrozous pallidus* and *A. dubiaquercus* share several penile characteristics (for example, a dorsally inclined baculum and dorsally ex-

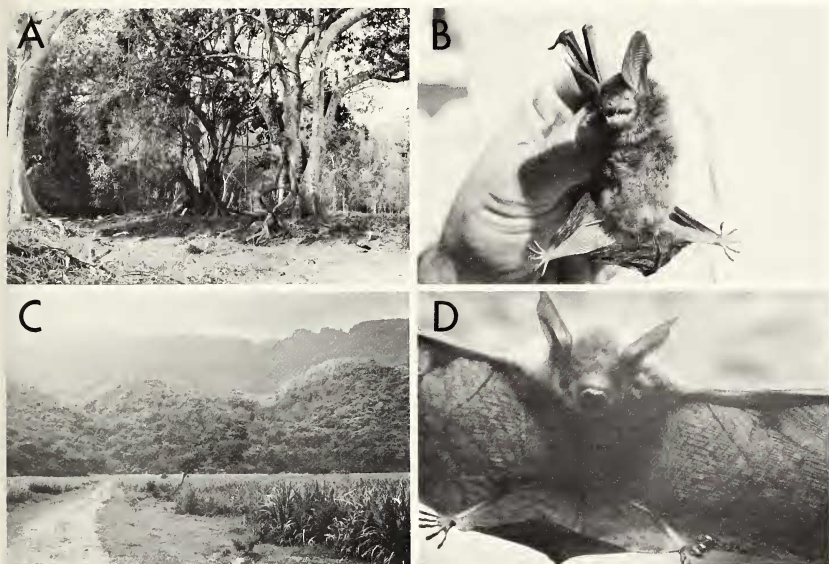

Fig. 4.—A) Tropical deciduous forest on Maria Madre, Islas Tres Marias. B) An *Antrozous dubiaquercus* taken in the habitat shown in A. C) Lowland tropical evergreen forest at Ojo de Agua, Veracruz. D) The *A. dubiaquercus* collected in the habitat shown in C. Photographs A and B by C. B. Robbins; C and D by D. S. Rogers.

posed urethra) not found in other New World vespertilionids, indicating that *Antrozous* is a monophyletic taxon; however, external differences between the male genitalia of the two species are marked. Pine et al. (1971:668) remarked, "although the difference between the penes of *A. dubiaquercus* and *A. pallidus* are rather substantial when one considers that there seems to be little variation in penis structure even between genera in other subfamilies of vespertilionid bats (as far as known), we prefer not to use phallic evidence to determine the rank of *Bauerus* until something is known about the phallus of *Antrozous koopmani*."

Karyotypes of *A. pallidus* and *A. dubiaquercus* also differ. *Antrozous pallidus* possesses a  $2n$  of 46 and FN of 50 (Baker and Patton, 1967; Bickham, 1979) whereas *A. dubiaquercus* has  $2n = 44$ , FN = 52. If the karyotype of *A. dubiaquercus* were derived from a chromosomal complement consisting of more acrocentric elements, such as that of *A. pallidus* (the direction of chromosomal evolution hypothesized by Bickham, 1979, for the karyotypic group containing *A. pallidus*), a minimum of two chromosomal changes could account for the

karyotypic differences between the two species. A Robertsonian fusion of two small acrocentric elements and a pericentric inversion or heterochromatic addition in a second small acrocentric chromosome in the karyotype of *A. pallidus* would yield a karyotype similar to that of *A. dubiaquercus*. Chromosomal banding studies might reveal other rearrangement differences between these taxa. Intrageneric karyotypic variation in vespertilionid bats, however, is uncommon (see review by Bickham, 1979).

#### TAXONOMIC CONCLUSIONS

We prefer to assign subspecific epithets to biological subunits of species, rather than to catalogue geographic variants (see definition of subspecies by Lidicker, 1962). Given the extensive variation among populations of *A. dubiaquercus* and the lack of specimens, it is not possible to identify biologically meaningful subunits; moreover, the present arrangement of subspecies masks the pattern of variation (or lack thereof) among specimens. Accordingly, we regard *A. dubiaquercus* as monotypic.

The chromosomal, cranial (described in detail by Van Gelder, 1959; Pine, 1966, 1967), postcranial (Martin, 1974), and phallic differences between *Antrozous* (*Antrozous*) *pallidus* and *Antrozous* (*Bauerus*) *dubiaquercus* are at least as great as those found among most genera of vespertilionid bats and indicate a long history of genetic isolation. We believe that *Bauerus* is a distinct genus. *Antrozous koopmani* apparently lacks the diagnostic third lower incisor of *Bauerus* (Silva Tauboda, 1976) and we tentatively retain this species in *Antrozous*. The following synonymy applies to *Bauerus*.

#### *Bauerus dubiaquercus* (Van Gelder)

1959. *Antrozous* (*Bauerus*) *dubiaquercus* Van Gelder, Amer. Mus. Novit., 1973:2, 19 November.  
1966. *Baeodon meyeri* Pine, Southwestern Nat., 11:308, 30 June.  
1967. *Antrozous* (*Bauerus*) *meyeri*, Pine, Southwestern Nat., 12:485, 31 December.  
1969. *Bauerus dubiaquercus*, White, Misc. Publ. Mus. Nat. Hist., Univ. Kansas, 51:277, 11 July.  
1971. *Antrozous dubiaquercus meyeri*, Pine et al., J. Mamm., 52:665, 16 December.

#### ACKNOWLEDGMENTS

Permits to collect specimens in Mexico were kindly supplied by Ignacio Ibarrola Bejar and Mario Luis Cossio Gabucio, of the Departamento de Conservacion de la Fauna Silvestre. M. A. Bogan, A. L. Gardner, D. J. Schmidly, and J. W. Sites, Jr., read an earlier draft of this manuscript and provided helpful criticism. Special thanks are extended to D. S. Rogers, R. C. Dowler, and C. B. Robbins for their enthusiastic assistance and companionship in the field. A. L. Gardner provided laboratory assistance with the karyotypic analyses. This research was partially supported by NSF Grant DEB 77-13467 to J. W. Bickham, the Texas Agricultural Experiment Station (project H-1977 to D. J.

Schmidly), the American Museum of Natural History, and the Carnegie Museum of Natural History.

### LITERATURE CITED

- BAKER, R. J. 1970. The role of karyotypes in phylogenetic studies of bats. Pp. 303–312, in *About bats; a chiropteran symposium* (B. Slaughter and D. W. Walton, eds.), Southern Methodist Univ. Press, Dallas, 339 pp.
- BAKER, R. J., AND J. L. PATTON. 1967. Karyotypes and karyotypic variation of North American vespertilionid bats. *J. Mamm.*, 48:270–286.
- BICKHAM, J. W. 1979. Chromosomal variation and evolutionary relationships of vespertilionid bats. *J. Mamm.*, 60:350–363.
- BOGAN, M. A. 1978. A new species of *Myotis* from the Islas Tres Marias, Nayarit, Mexico, with comments on variation in *Myotis nigricans*. *J. Mamm.*, 59:519–530.
- COCKRUM, E. L. 1962. Laboratory and field manual for introduction to mammalogy. Ronald Press Co., New York, 116 pp.
- GOODNIGHT, J. H. 1979. TTEST procedure. Pp. 425–426, in *SAS user's guide, 1979 edition* (J. T. Helwig and K. A. Council, eds.), SAS Institute Inc., Raleigh, 494 pp.
- HANDLEY, C. O., JR. 1959. A revision of American bats of the genera *Euderma* and *Plecotus*. *Proc. U.S. Nat. Mus.*, 110:95–246.
- JONES, J. K., JR., P. SWANEPOEL, AND D. C. CARTER. 1977. Annotated checklist of the bats of Mexico and Central America. *Occas. Papers Mus., Texas Tech Univ.*, 47:1–35.
- KOOPMAN, K. F., AND J. K. JONES, JR. 1970. Classification of bats. Pp. 22–28, in *About bats; a chiropteran symposium* (B. Slaughter and D. W. Walton, eds.), Southern Methodist Univ. Press, Dallas, 339 pp.
- LIDICKER, W. Z., JR. 1962. The nature of subspecies boundaries in a desert rodent and its implications for subspecies taxonomy. *Syst. Zool.*, 11:160–171.
- MARTIN, C. O. 1974. Systematics, ecology, and life history of *Antrozous* (Chiroptera: Vespertilionidae). Unpubl. M.S. thesis, Texas A&M Univ., College Station, 256 pp.
- PATTON, J. L. 1967. Chromosome studies of certain pocket mice, genus *Perognathus* (Rodentia: Heteromyidae). *J. Mamm.*, 48:27–37.
- PINE, R. H. 1966. *Baeodon meyeri* (Chiroptera: Vespertilionidae) a new species of bat from Veracruz. *Southwestern Nat.*, 11:308–310.
- . 1967. *Baeodon meyeri* Pine (Chiroptera: Vespertilionidae) referred to the genus *Antrozous* H. Allen. *Southwestern Nat.*, 12:484–485.
- PINE, R. H., D. C. CARTER, AND R. K. LAVAL. 1971. Status of *Bauerus* Van Gelder and its relationships to other nyctophiline bats. *J. Mamm.*, 52:663–669.
- ROHLF, F. J. 1971. Perspectives on the application of multivariate statistics to taxonomy. *Taxon*, 20:85–90.
- ROHLF, F. J., AND J. KISHPAUGH. 1972. Numerical taxonomy system of multivariate statistical programs. State Univ. New York at Stony Brook, Stony Brook, 87 pp.
- SILVA TABOADA, G. 1976. Historia y actualizacion taxonomica de algunas especies antillanas de murcielagos de los generos, *Pteronotus*, *Brachyphylla*, *Lasiurus*, y *Antrozous* (Mammalia: Chiroptera). *Poeyana*, 153:1–24.
- VAN GELDER, R. G. 1959. Results of the Puritan-American Museum of Natural History expedition to western Mexico. 8. A new *Antrozous* (Mammalia, Vespertilionidae) from the Tres Marias Islands, Nayarit, Mexico. *Amer. Mus. Novitates*, 1973:1–14.
- WHITE, J. A. 1969. Late Cenozoic bats (subfamily Nyctophilinae) from the Anza-Borrego Desert of California. Pp. 275–282, in *Contributions in mammalogy: a volume honoring Professor E. Raymond Hall* (J. K. Jones, Jr., ed.), *Misc. Publ. Mus. Nat. Hist., Univ. Kansas*, 51:1–428.